

# instructions for

## Model 2800M Integrating Sound Level Meter

and

## Model OB-100M Octave Band Filter

and

## Model OB-300M 1/1 - 1/3 Octave Band Filter

MODEL 2800M IMPULSE INTEGRATING SOUND LEVEL METER  
WITH THE OB-100M/OB-300M  
TABLE OF CONTENTS

I.	INTRODUCTION TO THE MODEL 2800M	1
A.	Assembling the Meter	1
	Microphone Handling and Storage	1
II.	ABOUT THE METER	2
A.	The Display	2
B.	Meter Controls	3
	HOLD Button	3
	RESET Button	3
	RUN Button	3
	PRINT Button	3
	BATTERY Button	3
	RESPONSE Switch	4
	WEIGHTING Switch	4
	MODE Switch	4
	dB RANGE Switch	5
	POWER Switch	5
C.	Overload Detection	5
D.	Output Jacks	6
	PRINT	6
	DC	6
	AC	6
	DATA	6
E.	Internal Switches	7
	Baud Rate	7
	Display Time	7
F.	Printout	8
	Downloading To Hyperterminal	10
III.	CHECKING THE METER INTEGRITY	11
A.	Battery Check	11
B.	Calibration	11
IV.	GENERAL OPERATING CONSIDERATIONS	12
A.	Meter / Microphone Placement	12
B.	Background Noise	12
C.	Wind Screen Effects	13
D.	Chart Recording	14
V.	TECHNICAL INFORMATION	16
A.	Principles of Operation	16
B.	Microphone	17
C.	Microphone Preamp Extension Cables	17
D.	Input Buffer Circuitry	18
E.	Weighting Characteristics	18
F.	Internal Electrical Noise	19
G.	Response Charts	20



053-048 Rev A  
08/00

VII. INTRODUCTION TO THE MODEL OB-100M ..... 26

VIII. ABOUT THE FILTER ..... 26

- A. Filter Controls ..... 26
  - POWER Switch ..... 26
  - START Buttons ..... 26
  - 20 dB Button ..... 26
  - TIME ..... 26
- B. Filter Connector ..... 27

IX. GENERAL OPERATING PROCEDURE ..... 27

- A. Operational Check ..... 27
- B. Taking a Measurement ..... 28
  - MANUAL Filter Operation ..... 29
  - AUTO Filter Operation ..... 29
- C. Reviewing the Data ..... 29

X. TECHNICAL INFORMATION ..... 30

XI. SPECIFICATIONS ..... 31

XII. INTRODUCTION TO THE MODEL OB-300M ..... 32

XIII. ABOUT THE FILTER ..... 32

- A. Filter Controls ..... 32
  - POWER Switch ..... 32
  - START Buttons ..... 32
  - 20 dB Button ..... 32
  - MODE Switch ..... 33
  - TIME ..... 33
- B. Filter Connector ..... 33

XIV. GENERAL OPERATING PROCEDURE ..... 34

- A. Operational Check ..... 34
- B. Taking a Measurement ..... 35
  - MANUAL Filter Operation ..... 35
  - AUTO Filter Operation ..... 35
- C. Reviewing the Data ..... 36

XV. TECHNICAL INFORMATION ..... 36

XVI. SPECIFICATIONS ..... 37

XVII. ADDENDUM FOR THE MODEL 2800M-5 ..... 39

SERVICE AND WARRANTY POLICY ..... 40

- Service Policy ..... 40
- Warranty Policy ..... 40

## I. INTRODUCTION TO THE MODEL 2800M

The Metrosonics Model 2800M functions as a Sound Level Meter, Impulse or Integrating Sound Level Meter. In all modes, the Model 2800 delivers Type 2 accuracy for noise measurements and statistical analysis. Applications include laboratory, industrial, community and audiometric measurement and analysis.

The Model 2800M is a user-friendly hand held meter with an LCD display that provides a numerical and bar graph readout. It is housed in a tough injection molded plastic case with internal shielding. The meter is configured and operated with easy-to-use slide switches and push buttons. Two output jacks are provided for connecting to external peripherals such as chart recorders or printers.

Plug in the Model OB-300M combination 1/3 - 1/1 Octave Filter Set and create a 1/3 or 1/1 octave band analyzer covering 33 bands from 12.5 Hz to 20 kHz. The addition of the Model OB-100M Octave Filter Set will create an octave band analyzer covering 10 bands from 31.5 Hz to 16 kHz.

If sound measurements need to be made from a distance, simply remove the microphone/pre-amplifier and insert an ICM-2 (2 foot), an ICM-10 (10 foot) or an ICM-50 (50 foot) extension cable. Distances of up to 100 feet can be accommodated by adding two ICM-50 (50 foot) extension cables in series.

### A. Assembling the Meter

The microphone and preamplifier must be assembled prior to making any measurements.

#### Microphone Handling and Storage

The microphones used with the model 2800M will provide years of reliable use, but certain precautions should be followed with regard to handling and storage.

1. Never remove the microphone grid. This will expose the diaphragm, making it susceptible to physical damage. When removing a microphone from the preamplifier be careful not to unscrew only the grid.
2. Never touch the diaphragm.

3. Electret (prepolarized) microphones should never be stored at high temperatures, as long term degradation of the polarization charge may occur. This results in a decrease in microphone sensitivity.
4. An electret microphone should be stored in its protective box when not in use for long periods of time.

To attach the microphone to the preamplifier, screw the microphone onto the threaded end of the preamplifier. Attach the preamplifier to the meter by placing the connector ends together and rotating the preamplifier until it drops onto the meter. Finger tighten the black locking ring by screwing it onto the meter. See Figure 1.

## II. ABOUT THE METER

### A. The Display

The LCD display contains both a numeric readout and a bar indicator along with BAT (battery), RUN, HLD (hold), and OL (overload) annunciators. The rate at which the numeric display is updated depends upon the setting of a switch located in the battery compartment. Either a one-second or a one-quarter second display rate can be selected.

The bar indicator portion of the display will indicate the current SPL (Sound Pressure Level), except when the BATTERY button is pressed. (See III. A., Battery Check). When using the bar indicator for SPL, the 0 to 60 range of the bar indicator represents the selected range on the Range switch. If on the 80 to 140 range, for example, the bar indicator represents 80 to 140 dB.

The MODE switch selects what data is to be displayed in the digital portion of the readout (i.e. SPL, MIN, MAX etc.). Sound levels are shown to the nearest 0.1 dB. RUN time (or OL time) is displayed in MIN:SEC if the total time is less than 20 minutes, and in HRS:MIN if the total time is greater than 20 minutes.

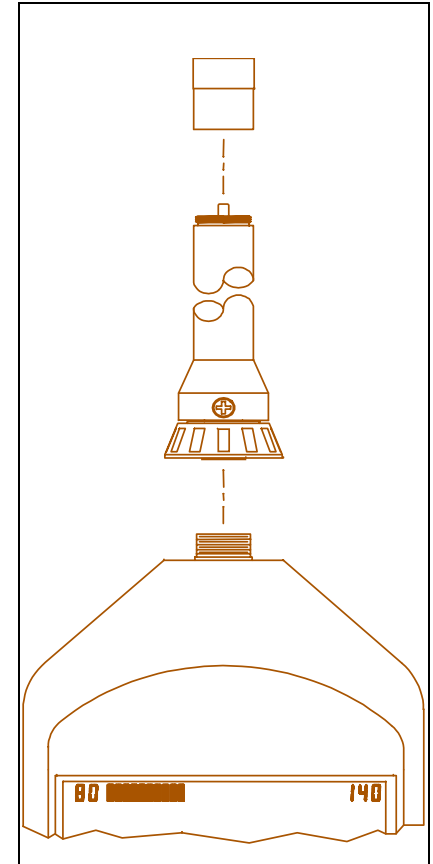

Figure 1 Mic/Preamp Assembly

## B. Meter Controls

### HOLD Button

When the HOLD button is depressed, the current value in the numerical portion of the display is frozen and the HLD annunciator appears in the display. If the meter is in the RUN mode while or prior to pressing the HOLD button, the last stored values of MIN, MAX, SEL, TIME, and LEQ that occurred can be viewed. Simply use the MODE switch to select the value of interest. Pressing HOLD will NOT stop an LEQ measurement accumulation. It simply saves the current value for viewing.

HOLD is a toggle function. To exit the HOLD mode simply press HOLD again.

### RESET Button

To reset ALL data stored within the Model 2800M, press the RESET button. This will erase all stored data prior to taking new readings.

**NOTE:** Pressing RESET while the RESPONSE is set to PEAK only resets PEAK. All other data remains unaffected.

### RUN Button

The RUN indicator will appear in the display when the RUN button is pressed. The meter will begin integration at this point. MAX, MIN, SEL, TIME, and LEQ data is collected only during the RUN mode. Pressing the RUN button again will exit the RUN mode and the instrument will enter the PAUSE mode where MAX, MIN, SEL, TIME, and LEQ are held at their last values. Press the RUN button again to continue updating MAX, MIN, SEL, TIME, and LEQ. Press RESET to erase all existing data before taking new data.

### PRINT Button

If the Model 2800M is connected to a printer via the PRINT output jack, pressing the PRINT button will send all of the current data stored in the meter to the printer. During the printout period, the numeric display will read 'Prn'. To stop the printout just press the print button again. (See Figure 5, sample Printout.)

### BATTERY Button

Pressing the BATTERY button will indicate relative battery strength in the bar portion of the display. This button may be pressed at any time without affecting the meter signal processing. (See III. A., Battery Check for more information.)

## RESPONSE Switch

The RESPONSE switch controls the rate at which the meter responds to changing input signals. Most sound measurements are done with the response set to SLOW.

The FAST response is generally used when measuring short duration noises such as moving vehicles. PEAK is only used in the SPL mode and has no meaning when making integrated measurements. The RESPONSE switch positions are as follows:

SLOW - 1 second time constant. (See Figure 14)

FAST - 125 millisecond time constant. (See Figure 15)

PEAK - 50 microsecond rise time constant with the peak sound level being captured and held until the RESET button is pressed. (See Figure 16)

**NOTE:** Pressing the RESET button while in the PEAK response will not clear out the integration data.

IMPulse - 35 millisecond rise time constant with a decay rate of 2.9 dB/sec. (See Figures 17 and 18)

## WEIGHTING Switch

The WEIGHTING switch controls the frequency response of the meter. Weightings A, B, C, or LINear (flat) may be selected. (See V. E., Weighting Characteristics for further details.)

## MODE Switch

The MODE switch selects either the sound pressure level or the integrating function to be shown in the digital portion of the display. (MIN, MAX, SEL, TIME, and LEQ will only have values if the meter has been in the RUN mode accumulating data.)

SPL - Sound Pressure Level will be displayed. (SPL is also always shown in the display bar indicator.)

MAX - The Maximum Sound Pressure Level obtained in the RUN mode is shown in the numeric display.

MIN - The Minimum Sound Pressure Level obtained while in the RUN mode is shown in the numeric display.

SEL - The Sound Exposure Level, or sound energy averaged over one second that is equivalent to the energy accumulated while in the RUN mode, is displayed.

TIME -The total RUN time will be displayed. The format is MIN:SEC for any time less than 20 minutes and HRS:MIN for any time greater than 20 minutes.

LEQ - The average integrated sound level accumulated while in the RUN mode is displayed.

#### dB RANGE Switch

The displayed range of the Model 2800M is 60 dB and is switchable between the following: 20-80 dB, 40-100 dB, 60-120 dB, or 80-140 dB.

#### POWER Switch

When turned ON, the meter begins with all data reset to zero and is in the pause mode (non-RUN mode). By switching the unit OFF, all accumulated data is cleared from the memory.

#### C. Overload Detection

In the SPL mode, the overload indicator (OL) is displayed whenever the incoming signal saturates (overloads) the circuitry. It appears as OL in the upper right-hand corner of the display. If the OL indicator is on, increase the dB RANGE switch until the OL condition is removed causing OL to disappear.

The Model 2800M also stores the length of time that the OL condition existed during the RUN mode. If an OL condition occurs while in the RUN mode, the OL indicator will come on and remain on until RESET is pressed. The time duration of the overload condition can be viewed by sliding the MODE switch to TIME and then holding the BATTERY button in. The overload time will also be printed on the hard copy printout.

**Note:** OL can be reset for use in the SPL mode without losing accumulated data. Place the meter into PAUSE, slide the RESPONSE switch to PEAK and then press the RESET button. Then return the RESPONSE switch back to the desired position. OL is now reset for normal use in the SPL mode only. It still remains latched when switched back to either the SEL, TIME, or LEQ mode.

#### D. Output Jacks

All output jacks use a 3.5 mm stereo plug. (See Figure 2, Output Jack Connections.) The following describes each output function:

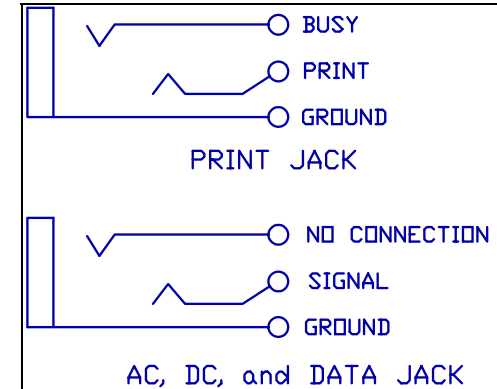

Figure 2. Output Jack Connections

- PRINT** - Pressing the PRINT button causes serial ASCII data to be transmitted from the print jack at appropriate RS-232 levels. This data may be sent to a serial printer or a computer. The baud rate is determined by two switches located in the battery compartment. (See Figure 4, Battery Compartment Internal Switches, for switch settings).
- DC** - The Sound Pressure Level (SPL) over the 60 dB range selected is linearly represented by a 0 to 1 volt DC output. Zero volts is equal to the bottom of the range and 1 volt is equal to full scale. This output is primarily provided for connecting to a 0 to 1 volt input chart recorder. (See IV. D., Chart Recording and Figure 6, Chart Recording of SPL)
- AC** - This jack furnishes an amplified SPL, (either weighted or unweighted), depending on the WEIGHTING switch setting. The full span of 60 dB is represented between 3.16 millivolts and 3.16 volts RMS.
- DATA** - When the Model 2800M is in the RUN mode, an SPL reading will be serially transmitted through the DATA jack at a rate of 16 times per second. To make use of this function, the meter range switch must be set in one of its two highest positions.

The data is an 8-bit signal proportional to the integrated sound level for the last 1/16 second. The signal is normally at +6.5 volts. If the meter is in the RUN mode, data is sent as in Figure 3. Signal description is as follows:

The signal goes to -6.5 volts every 0.55 msec.  
 If the bit is a 0 it will return to plus after 0.1 msec.  
 If the bit is a 1 it will return plus after 0.45 msec.  
 The signal is sent least significant bit first.  
 The resolution is 3/8 dB.

All 0's = 30 dB if the meter is set to the 60 - 120 dB range.  
 50 dB if the meter is set to the 80 - 140 dB range.  
 All 1's = 30 dB + 95.6 dB when set to the 60 - 120 dB range.  
 50 db + 95.6 dB when set to the 80 - 140 dB range.

The example in Figure 3 is 10101100 binary = 172 decimal. The level is  $(172 \times 3/8) + 50 = 114.5$  dB when on the 80 - 140 dB range.

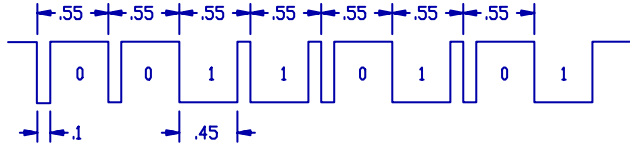

Figure 3. Data Jack Format

#### E. Internal Switches

There is an internal switch located in the battery compartment that is accessible to the user. (Refer to Figure 4.)

**Baud Rate** - Actuators 1 and 2 of the dip switch, located through the hole in the lower left, control the baud rate at which the meter transmits data to a printer. Baud rates available are 300, 600, 1200, and 2400.

**Display Time** - The recessed dip switch controls the rate at which the display updates. The options are 1.0 second or 0.25 second.

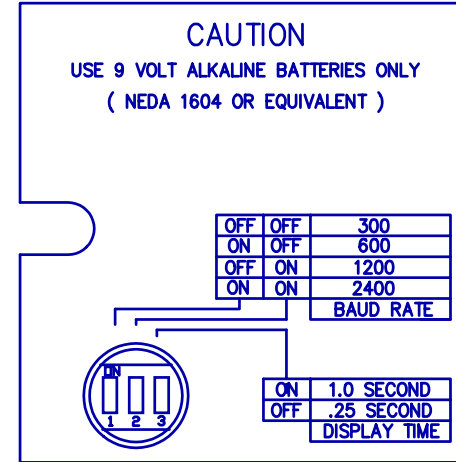

Figure 4. Battery Compartment Internal Switches.

#### F. Printout

The Sound Level Meter produces a hard-copy of the information accumulated during the total RUN MODE period. When used with the filter set OFF, this information includes :

1. Meter WEIGHTING and RESPONSE settings.
2. LEQ, MAX, MIN, and SEL Levels.
3. RUN TIME and OL TIME.
4. Table of EXCEEDANCE LEVELS (dB)\*

\*EXCEEDANCE LEVELS: Tabulated from 1 to 99, the sound level that was exceeded for that percentage of run time. (See Figure 5, Sample Printout.)

If an OB-100M or OB-300M is actively used as part of the sound measuring system, all of the information above the OCTAVE FILTER SET header will pertain only to the last Octave Band measurement. This allows the user to perform, for example, a 500 Hz Octave Band Measurement on "A" Weighting, "SLOW" Response, and obtain a printout that includes proper switch settings and exceedance levels for that frequency.

**NOTE:** For forty column printers, the Sound Level Meter allows for a compressed print mode. Pressing the HOLD button before printing causes the meter to send a printer control code [ LPRINT CHR\$(15) ] that produces a compressed print form for many printers. Consult your printer manual for details.

METROSONICS 2800 IMPULSE INTEGRATING SOUND LEVEL METER  
DATE: \_\_\_\_\_ SERIAL NO. \_\_\_\_\_ CALIBRATED: \_\_\_\_\_

LINEAR WEIGHTING / SLOW RESPONSE  
LEQ (dB) MAX (dB) MIN (dB) SEL (dB) RUN-TIME OL-TIME  
100.8 107.2 49.4 116.3 :00:36

EXCEEDANCE LEVELS (dB)

	0	1	2	3	4	5	6	7	8	9
L00	107	107	107	107	107	107	107	107	107	107
L10	107	107	107	107	107	107	107	107	107	107
L20	107	106	106	106	106	105	104	103	101	100
L30	98	97	95	94	93	92	91	90	89	89
L40	89	89	88	88	88	88	88	88	88	88
L50	88	88	88	88	88	88	88	88	87	87
L60	87	87	87	87	87	87	86	84	83	81
L70	80	78	77	75	74	73	71	70	68	67
L80	65	64	63	62	61	59	58	57	56	56
L90	55	54	53	53	52	52	51	51	50	50

MODEL OB-300 1/1-1/3 OCTAVE FILTER SET - SERIAL NO. \_\_\_\_\_

FREQ (Hz)	LEQ (dB)	MAX (dB)	MIN (dB)	SEL (dB)	RUN-TIME	OL-TIME
12.5	70.1	70.8	70.1	77.8	:00:05	
16	88.0	88.8	86.9	92.3	:00:02	
20	106.2	107.2	104.6	111.3	:00:03	
25	105.1	108.3	93.7	117.1	:00:15	:00:05
31.5	92.3	97.4	84.7	97.3	:00:03	
40	76.6	80.9	70.4	81.0	:00:02	
50	66.2	75.7	53.6	76.8	:00:11	
63	53.3	56.2	51.7	59.2	:00:03	
80	65.9	71.6	60.3	72.1	:00:04	
100	70.0	70.8	68.9	75.8	:00:03	
125	88.2	89.2	86.9	92.7	:00:02	
160	115.3	120.3	104.6	127.5	:00:16	
200	111.2	116.2	106.4	116.5	:00:03	
250	95.2	103.1	86.2	103.5	:00:06	
315	74.6	83.2	61.4	85.9	:00:13	
400	70.9	71.9	69.7	76.0	:00:03	
500	88.8	89.9	87.7	92.7	:00:02	
630	107.2	108.3	105.7	113.1	:00:03	
800	98.2	103.8	91.8	104.3	:00:04	
1,000	77.9	88.4	71.2	89.2	:00:13	
1,250	87.8	88.8	86.6	92.3	:00:02	
1,600	113.0	120.3	64.1	126.6	:00:23	:00:04
2,000	109.8	116.2	100.8	118.2	:00:07	:00:06
2,500	91.3	96.7	82.8	96.9	:00:03	
3,150	72.9	79.4	66.3	81.3	:00:06	
4,000	90.1	91.1	89.2	92.1	:00:01	
5,000	106.0	106.8	104.6	110.3	:00:02	
6,300	99.6	102.7	95.9	102.1	:00:01	
8,000	80.8	84.3	77.2	83.6	:00:01	
10,000	67.5	74.2	61.4	75.0	:00:05	
12,500	71.2	71.9	70.8	75.5	:00:02	
16,000	90.3	91.1	88.8	94.6	:00:02	
20,000	100.8	107.2	49.4	116.3	:00:36	

Figure 5. Sample Printout

INSTRUCTIONS TO DOWNLOAD INFORMATION FROM METROSONICS MODEL  
2800M INTEGRATING SOUND LEVEL METERS  
TO AN IBM-PC OR COMPATABLE USING HYPERTERMINAL

- 1 Connect the 2800M to the personal computer's serial port (Com 1 or Com 2) using either a P/N 059-749 (25 pin) or a P/N 059-750 (9 pin) cable. Connect the other end to the 2800M jack marked "PRINT".
- 2 Check that the 2800M is set to 2400 baud by removing battery cover and verifying that switches 1 and 2 are both set to "ON".
- 3 Start Hyperterminal.
- 4 The program should open and a dialog box should appear. Follow prompts and enter a name and select an icon for this setup. Click "OK".
- 5 Another dialog box should open labeled "Phone Number". On line marked "Connect Using" select either "Direct To Com 1" or "Direct To Com 2" depending on which serial port is being used. Then click "OK".
- 6 Another dialog box will open labeled "COM X Properties" where X will be either 1 or 2 depending on serial port selected. Select 2400 Bits per second, 8 Data Bits, No parity, 1 Stop Bit and set Flow Control to None. Click "OK".
- 7 To begin information transfer from 2800M, pull down transfer menu and click on "Capture Text". A dialog box will appear. Enter file name and path desired, then click button marked "Start". Press "print" button on 2800M. Text should appear in hyperterminal window.
- 8 After printout terminates, pull down transfer menu once again and highlight "Capture Text". Click on "Stop". Data is now stored in above named file and path. Hyperterminal window can now be saved and closed for later use.

III. CHECKING THE METER INTEGRITY

#### A. Battery Check

At any time (except during PRINT), the BATTERY push button can be pressed to get an indication of battery strength. The weaker of the two 9 volt batteries is shown on the bar indicator of the Model 2800M's display. Good batteries will be indicated with the bar extending well beyond the indicating arrow (5 on the 0-60 scale). If the bar falls below the indicating arrow, then **BOTH ALKALINE** batteries must be replaced. Because erroneous readings will occur if the battery check registers below the indicating arrow, it is good practice to perform a battery check before using the 2800M. Collected data and output port signals are NOT affected by performing a battery check.

#### B. Calibration

To check the calibration of the Model 2800M, perform the following procedure using a Metrosonics Model QC-10M Calibrator.

1. Perform a battery check.
2. Turn the Calibrator ON to produce the level specified on the label at 1 kHz.
3. An adapter is needed to mate the microphone size to the calibrator coupler. Insert it fully into the calibrator.
4. Place the Calibrator with adapter fully onto the microphone.
5. Set the Model 2800M to LIN, SLOW or FAST, the SPL mode, and the 60-120 range.
6. Use a small screwdriver to adjust the calibration potentiometer, located through the small hole on the left side of the meter, until the display matches the calibration level.

NOTE: Most calibrators are affected by changes in altitude and barometric pressure. However, barometric pressure has a negligible effect on the Metrosonics QC-10M. The rated SPL is set at standard barometric pressure at sea level (760 mm Hg).

#### IV. GENERAL OPERATING CONSIDERATIONS

Before taking measurements with the Model 2800M, there is a series of quick checks and considerations that should be performed or noted. After switching the unit ON, the batteries should be checked (and replaced if needed).

Although the Model 2800M will maintain accurate calibration over a long period of time, the calibration should be checked and the meter slightly adjusted, if necessary, before each use.

Set the RESPONSE, WEIGHTING, MODE, and dB RANGE switches as needed. Hold, set, or tripod mount the meter in the desired location. If performing integrating measurements, press the RUN button making sure "RUN" is indicated in the display. If the meter is in the RUN mode and you want to change a switch setting (particularly the dB RANGE switch), it is a good idea to stop accumulating data by entering the pause mode. To do this depress the RUN button again and "RUN" will disappear from the display. Change the desired switches, and then depress RUN again to continue accumulating data.

It is always a good idea to document all measurement conditions and meter settings for possible future needs. If a printer is used, the settings will all appear on the printout.

#### A. Meter / Microphone Placement

Whenever possible, the meter should be tripod-mounted in a relatively open area to minimize reflections from the body or other large reflective structures. Avoid placement against a wall or in a corner. If reflections are of concern, a microphone extension cable may be used for better microphone placement.

The QE7052 microphone cartridge used on the Model 2800M is a free-field microphone. Point it directly at the noise source ( 0 degrees ).

#### B. Background Noise

Background noise can cause considerable error in measurement when its intensity is close to that of a particular noise source of interest. When it is not possible to eliminate or reduce the background noise, use the curve shown in Figure 6 to correct for the effect of the background noise on the measurement.

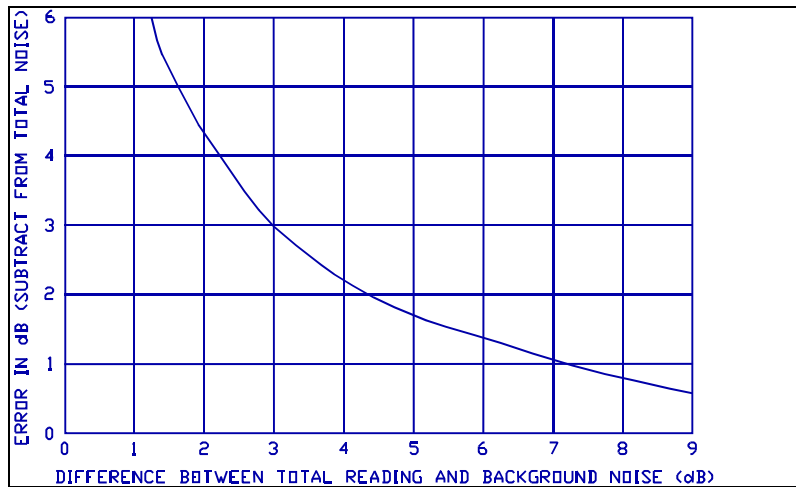

Figure 6 Effect of Background on Measurement

#### C. Wind Screen Effects

To prevent erroneous measurement of sound levels caused by wind blowing across the microphone, the use of a windscreen is recommended. The wind screen will reduce wind effects and will also help protect the microphone under dusty, oily, or humid conditions. Acoustic attenuation effects of the (WS-7) windscreen is shown in Figure 7.

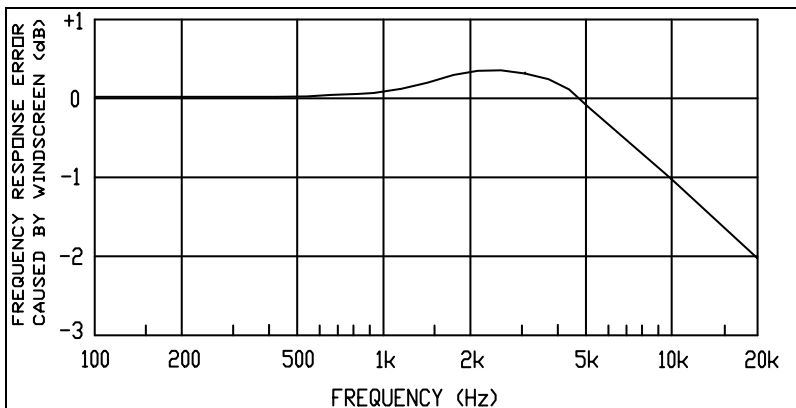

Figure 7. Acoustic Effect of WS-7 Windscreen

#### D. Chart Recording

The Model 2800M has a DC output that is linearly related to the 60 dB LCD analog bar movement as follows:

Analog Bar (dB)	0	10	20	30	40	50	60
DC Output (V)	.00	.17	.33	.50	.67	.83	1.00

This output, capable of driving up to 100 feet of shielded or twisted pair cable, is intended for use with a 0 to 1 volt DC input chart recorder that has an input impedance greater than 20K ohms.

Refer to Figure 8, Chart Recording of SPL. Connect the Model 2800M to the chart recorder input with proper polarity such that the pen is on the proper side of the chart paper with respect to time and that the pen moves in the proper direction with increasing dB level. Use a QC-10M acoustic calibrator to calibrate the chart recorder as follows:

1. Turn the meter to ON. Set the meter RESPONSE to FAST, WEIGHTING to A, MODE to SPL, and dB RANGE to 80-140.

**NOTE:** An adapter is needed to mate the microphone size to the calibrator coupler. Insert it fully into the calibrator.

2. Place the calibrator with adapter fully onto the microphone - do not turn the calibrator on yet. The meter shall read less than 80 dB which generates .00 volts DC out to the chart recorder. Adjust the zero control on the recorder so that the pen represents a relative dB of 0.
3. Turn the Calibrator ON to produce 114 dB at 1 kHz. Set the 2800M dB RANGE for the highest bar graph level without causing an overload. When set properly, the recorder pen should rise to the correct RELATIVE dB. (114 dB should cause the recorder pen to rise to the point indicated in Figure 8.) A small adjustment may be needed. Use the zero adjust on the recorder to do this.
4. Be sure to document all chart recorder settings and meter settings when taking measurements.

Note that any range position can be set on the Model 2800M and the 60 dB span of the meter range will always correspond to the full 60 dB range on the chart recorder.

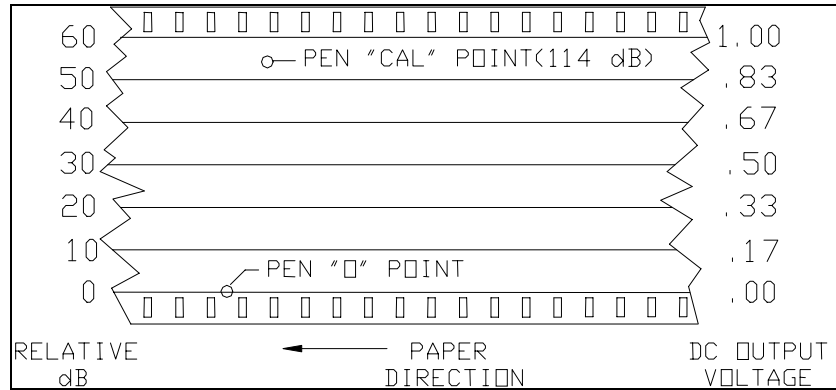

Figure 8. Chart Recording of SPL

## V. TECHNICAL INFORMATION

### A. Principles of Operation

The Model 2800M utilizes low noise, low power analog and digital integrated circuitry to ensure long battery life, maximum stability, and superior reliability over a wide range of environmental conditions. Figure 9 is a block diagram of the Model 2800M's internal circuit operations.

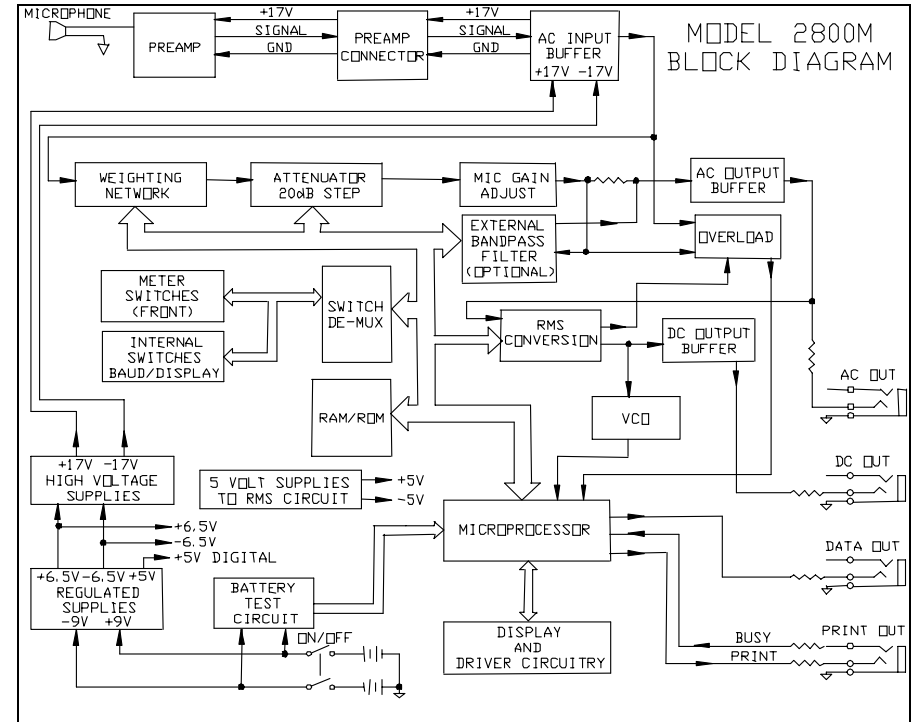

Figure 9. Block Diagram of the Model 2800M

## B. Microphone

The Model 2800M is designed to accept a prepolarized (electret) microphone Model QE7052 exclusively.

The microphone screws directly onto the preamp which, in turn, connects directly to the meter. The preamp converts the high output impedance of the microphone into a low output impedance. This allows the microphone to drive up to 100 feet of cable for remote operation.

A typical response curve for the .5 inch microphone is shown in Figure 10.

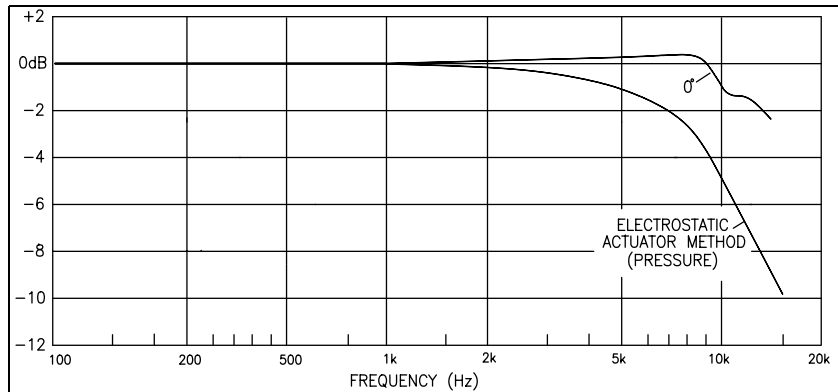

Figure 10. Typical Frequency Response for the Model QE7052 0.5 Inch Microphone

## C. Microphone Preamp Extension Cables

The microphone preamp converts the high output impedance of the microphone to a low output impedance, thus allowing the insertion of an extension cable of up to 100 feet in length between the preamp and meter. Metrosonics offers the following lengths of remote cables:

- # 59-733 ICM-10 10 Ft. Remote Cable.
- # 59-734 ICM-50 50 Ft. Remote Cable.
- # 59-899 ICM-2 2 Ft. Remote Cable.

The preamp is removable by turning the black plastic collar below the preamp housing counter-clockwise when viewed from the top of the meter.

## D. Input Buffer Circuitry

The high impedance input circuitry (1 Megohm in series with 0.1 MFD) will accept up to a 10 volt RMS signal. With the microphone and preamp removed, other transducer devices can be interfaced to give a dB readout on the meter.

When interfacing other input devices to the Model 2800M, Use pins 1 and 3 for the AC signal input. NEVER connect to pins 2 and 4.

To remove the preamp, keep the preamp housing steady while unscrewing the black plastic collar below the preamp housing. Turn in a counter-clockwise direction when viewed from the meter top.

To input an AC voltage electrically requires a special connector. Figure 11 describes the function of each of the pins within the meter input connector.

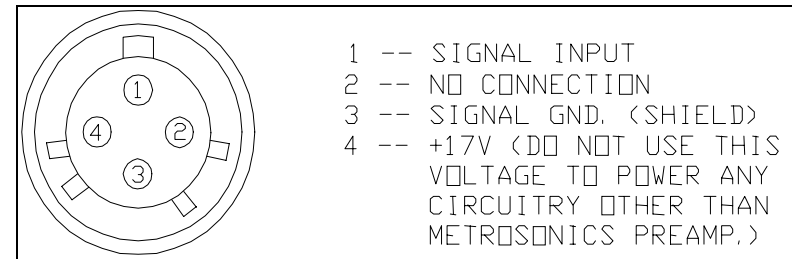

Figure 11 Meter Electrical Input (Direct)

## E. Weighting Characteristics

The weighting characteristics (frequency response) for A, B, C, and LInear are shown in Figure 12. The "A" weighting response emulates the response of the human ear and is used for most industrial and community noise measurements. "B" weighting is seldom used. "C" weighting is often used for measuring noise reduction in hearing protectors and for other scientific purposes. The "LInear" weighting has a flat frequency response over the range of human hearing and is useful in many applications such as audiometric analysis. It is also used when taking octave and 1/3 octave measurements.

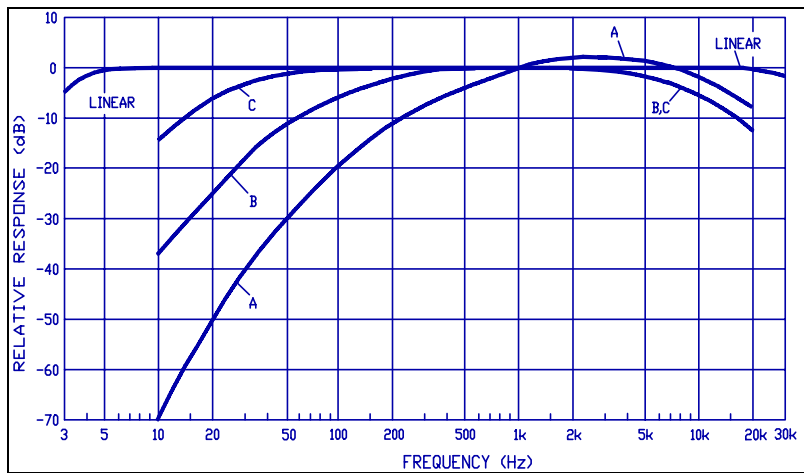

Figure 12 Weighting Characteristics

#### F. Internal Electrical Noise

The maximum measurable SPL of the 2800M Meter is 140 dB. When used with either the OB-100M or OB-300M filter set, the specific minimum measurable SPL's in each octave band are as shown in Figure 13. The inherent noise level is typically at least 5 dB below the RMS values shown in the table.

Octave Band	Weighting Scale			
	A	B	C	LIN
All Pass	35	37	40	48
31.5 and 63	10	25	35	37
125 and 250	21	27	31	31
500 and 1K	24	25	25	25
2K and 4K	27	25	25	25
8K and 16K	29	27	27	30

Figure 13. Minimum measurable SPL's for the Model 2800M with the QE7052 Microphone

#### G. Response Charts

Figures 14 through 18 are plots for each of the response settings of the meter. They show how the meter responds to a given sinewave input of varied pulse duration.

SLOW RESPONSE (1000 msec time constant) Figure 14.

FAST RESPONSE (125 msec time constant) Figure 15.

PEAK RESPONSE (50 microsecond time constant) Figure 16.

IMPULSE RESPONSE (35 msec rise time constant with a decay rate of 2.9 dB/sec) Figure 17 and Figure 18.

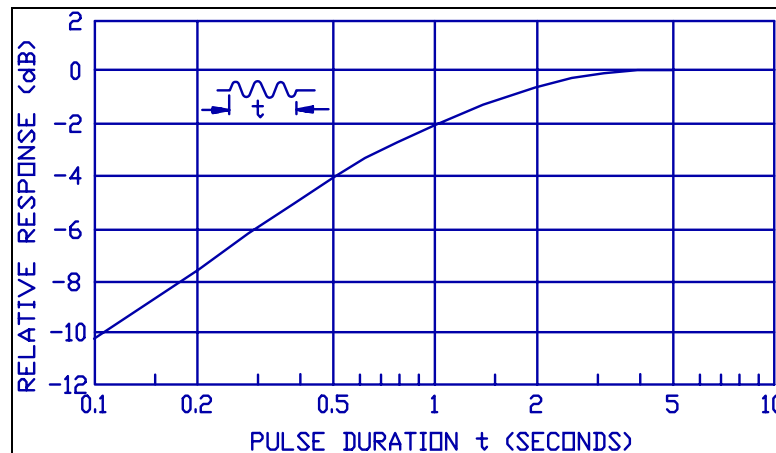

Figure 14. SLOW Response

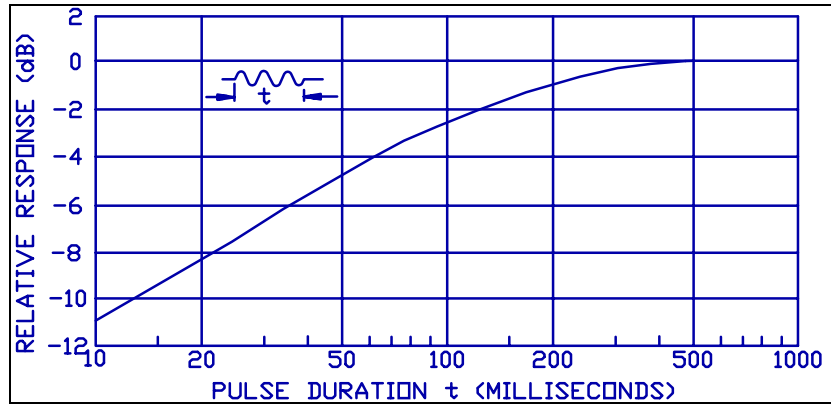

Figure 15 FAST Response

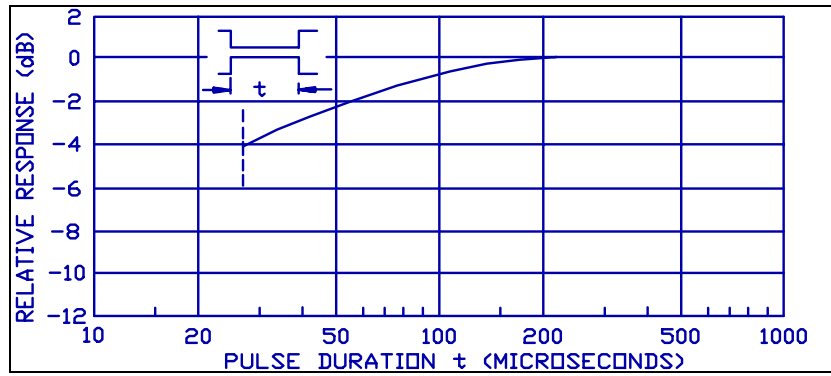

Figure 16 PEAK Response

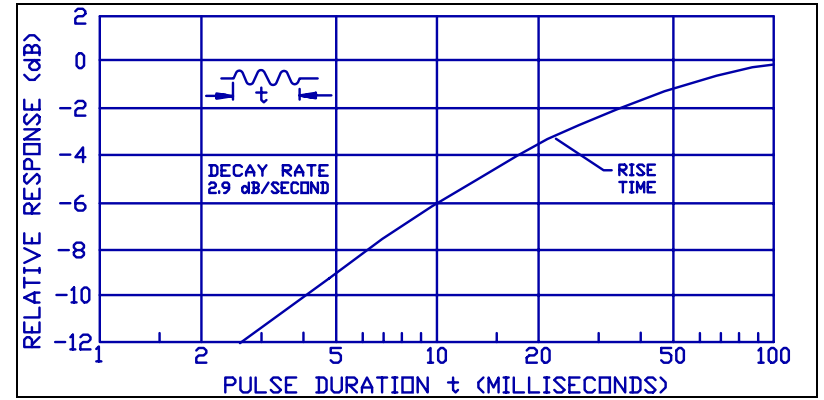

Figure 17 IMPULSE Response

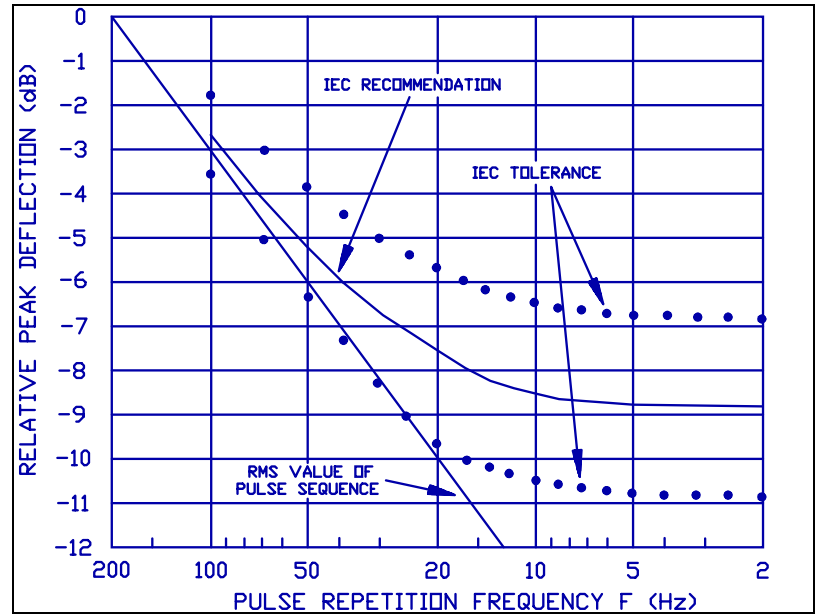

Figure 18 IMPULSE Response to Repeated Impulses

## VI. SPECIFICATIONS

**Standards:** Meets or exceeds ANSI S1.4-1983, Type 2 and relevant sections of IEC 651-1979, Type 2(I) and IEC 804-1985.

**Display:** 3 1/2 Digit Liquid Crystal Display with an additional Quasi-Analogue 60 dB indicator in 2 dB increments. Level display indicates to 0.1 dB resolution. Time display indicates either Min:Sec or Hr:Min. Annunciators are included for Battery Check, Hold, and Overload Indication.

**Printout:** When used with a printer, a one page printout is produced. It consists of the following: Heading; WEIGHTING and RESPONSE settings; LEQ, MAX, MIN, and SEL levels; RUN TIME and OL TIME ; EXCEEDANCE LEVELS (dB) with 1 dB resolution; and Filter Data for each frequency (LEQ, MAX, MIN, and SEL) along with the RUN TIME and OL TIME for each frequency.

**Modes of Operation:** Sound Pressure Level (SPL), Maximum Level (MAX), Minimum Level (MIN), Sound Exposure Level (SEL), and Equivalent Level (LEQ). Peak Level (PEAK) and Impulse Level (IMP) can also be measured.

**Minimum Measurement:** Meter only; With Model QE7052 Microphone -- 35 dBA. Using Linear Weighting with an Octave Filter Set; See Figure 13. The minimum measurement varies depending on the filter frequency selected.

**Maximum Measurement:** With Model QE7052 Microphone -- 120 dB with 20 dB Crest Factor. (140 dB if measuring a sinusoidal signal.) Overload indication will occur if upper range is exceeded.

**Frequency Weighting Networks:** A, B, C, and Linear. When using a filter set, any one of the weightings may be selected.

**Meter Response:** Slow, Fast, Impulse, and Peak. (The Peak onset time constant is less than 50 microseconds). Peak measurements may be made in either A, B, C, or Linear Weighting.

**Microphone:** Model QE7052, Removable .5-inch prepolarized condenser (electret) microphone.

**Preamp:** Removable; The input impedance is greater than 1G ohm in parallel with 35 pF. The preamp will drive up to 100 feet of cable.

**Meter Input:** The input impedance is 1 Megohm in series with 0.1 MFD. The maximum sinusoidal input voltage is 10V RMS.

**AC Output:** 3.16 V RMS at full scale (60 dB). (3.8 V RMS maximum) The output impedance is 3.2K ohms. Connected equipment should be at least 10K ohms. The output can be shorted without damaging the meter or changing the meter reading.

**DC Output:** 0 to 1.00V DC; 60 dB span. Each 0.167V change equals 10 dB. Connected equipment should be at least 10K ohms. The output can be shorted without damaging the meter or changing the meter reading.

**Print Output:** Serial output to printers or computers using RS-232 voltage levels. Selectable baud rates of 300, 600, 1200, or 2400. ASCII character format.

**Data Output:** Output transmission of real-time digital data occurs at a rate of 16 times per second using RS-232 voltage levels.

**Frequency Range:** 4 Hz (-3dB) to 50 kHz (-3dB) on linear weighting, meter only. (Subject to microphone limitations.)

**Reference Range:** 60 to 120 dB Range setting

**Reference SPL:** 94 dB

**Reference Frequency:** 1 kHz

**Reference Direction:** 0 Degree when using the Model QE7052 Microphone (Free Field). Sound is arriving from directly in front of the microphone diaphragm. (A Normal Line extending from the center of the microphone diaphragm.)

**Detector:** True RMS

**Detector Pulse Range:** 63 dB

**Detector Measuring Range:** From 0 dB to 40 dB on the painted scale (when measuring a signal with a 20 dB Crest Factor). The extra 20 dB (40 to 60) on top of the measuring range produces the 20 dB Crest Factor capability .

**Primary Indicator Range / Linearity Range:** 60 dB (The range as indicated by both the dB RANGE switch and the painted 60 dB scale.) Tested with a sinusoidal signal input.

**Level Linearity:** Inside the Primary Indicator Range. It is tested on the Reference Range (60 to 120 dB) with a sinusoidal input signal. Tolerance is +/- 1.0 dB referenced to 94 dB.

**Overload Indication:** The display annunciator (OL) indicates overload on the LCD.

**Attenuator Accuracy:** Referenced from the Reference Range and the Reference SPL (+34 dB on the painted meter scale). Within 0.7 dB from 31.5 Hz to 8 kHz.

**Warm-up Time:** 30 seconds.

**Integration Time (Settling Time):** 1 minute when measuring a short impulse. 5 seconds when integrating a constant input signal.

**Accuracy:** Within 0.7 dB at 25°C; Within 1.0 dB over the temperature range of -10°C to +50°C.

**Temperature Range:** Operation Temperature Range: -10°C to +50°C. Accuracy over the Operation Temperature is within +/- 0.5 dB. Storage Temperature Range (less batteries): -20°C to +60°C  
Do not exceed the Storage Temperature Range because possible damage to the unit may result.

**Operating Humidity:** Over a range of 30 to 90% relative humidity, the accuracy is within +/- 0.5 dB. Do not exceed 95% relative humidity because possible damage to the unit may result.

**Effect of Magnetic Fields:** A magnetic field of 1 Oersted (80A/m) at 60Hz produces a maximum reading of 40 dB on Linear Weighting.

**Effect of Electrostatic Fields:** Negligible.

**Batteries:** Two 9-volt alkaline batteries (NEDA 1604A) will provide approximately 20 hours of continuous operation. (10 hours with optional filter set.)

**Tripod Mount:** A threaded insert on back of the meter accepts a standard 1/4-20 tripod mounting screw.

**Size:** 3.3 x 8.2 x 1.8 inches (84 x 208 x 47mm) not including the height of the preamp.

**Weight:** 24 oz. (680g) including the preamp and batteries.

## VII. INTRODUCTION TO THE MODEL OB-100M

The Metrosonics Model OB-100M Octave Filter is a plug-in module containing a selectable set of filters. The OB-100M meets the most stringent requirements of ANSI S1.11-1986 and IEC R225-1966 for octave band filters. The unit contains ten selectable filter ranges from 31.5 Hz to 16 kHz center frequencies with full octave band width.

Primary uses include frequency analysis for product noise emission, material acoustics, community noise, audiometer calibration and analysis of audiometric rooms. Active filters are employed throughout the Model OB-100M, thus permitting the unit to have both high accuracy and compact size.

## VIII. ABOUT THE FILTER

### A. Filter Controls

#### POWER Switch

A three position slide switch that does the following:

OFF -- Disconnects the filter circuitry from the attached sound level meter. With this switch in the off position, the OB-100 does not use power from the meter batteries.

MANUAL -- Filter frequency selection is performed with two push buttons (START Buttons).

AUTO -- Unit automatically cycles through the desired filter frequencies while storing sample information for each frequency during the RUN mode.

#### START Buttons

Allow the user to cycle through the different bandpass filters. The two buttons allow manual frequency control (in MANUAL Mode) or frequency direction control (in AUTO Mode).

#### -20 dB Button

When this button is depressed, the output of the filter is amplified by exactly 10 times (20 dB) and then fed back to the sound level meter. Therefore, 20 dB has to be subtracted from the meter reading when using this button.

#### TIME

A screwdriver adjustment to control the automatic cycle time of each filter frequency from approximately 5 to 30 seconds.

## B. Filter Connector

The 30 pin connector on the top of the filter is used for connecting the filter to the sound level meter. Figure 19 shows the pinout for the filter connector.

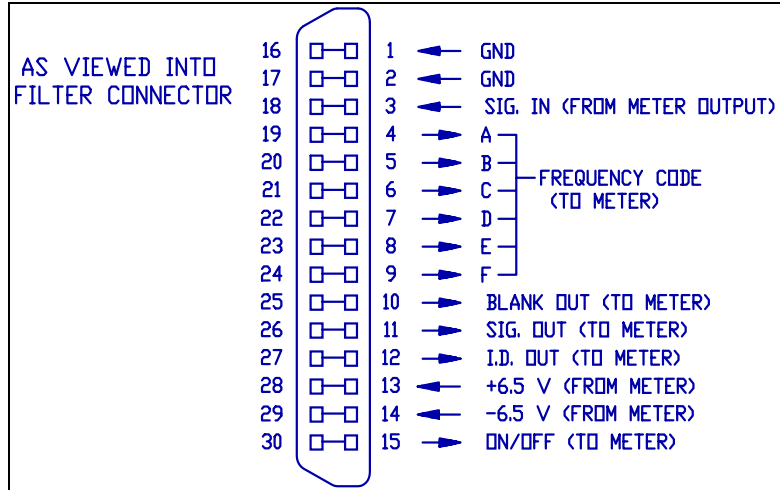

Figure 19 OB-100M External Filter Connector (Located on top of filter)

## IX. GENERAL OPERATING PROCEDURE

The Model 2800M-100M Octave Band Analyzer is made up of the Model 2800M Impulse Integrating Sound Level Meter and the OB-100M Octave Filter Set. The two units are connected together with the long captive screw provided with the filter box. The General Operating Considerations for the Model 2800M (Section IV) are basically the same when using the Model OB-100M with the meter.

### A. Operational Check

The Model 2800M should be calibrated as outlined in the meter section of the manual (Section III, B, Calibration) while the OB-100M is OFF. The OB-100M has a fixed input to output voltage ratio of approximately 1 (0 dB) at each center frequency and requires no adjustment. After the meter is calibrated, check the filter for proper operation as follows:

1. Read the calibrator 1 kHz output level. Set the meter dB RANGE switch so that the calibrator level will indicate within the upper 20 dB of the meter display. Set the RESPONSE switch to FAST, WEIGHTING switch to LIN and MODE switch to SPL. Turn the POWER switch to ON.
2. Set the OB-100M POWER switch to MANUAL and press the RUN button to place the meter into the RUN mode. Then use the two direction buttons to select the 1 kHz filter.
3. Place the calibrator and adapter onto the microphone. Turn the calibrator ON. A meter reading that is very close to the level listed on the calibrator should result. An error of +/- 0.5 dB is acceptable. This is due to the center frequency filter tolerance of +/- 0.5 dB maximum.
4. Change the OB-100M filter frequency first to 500 and read the display. Then change to 2k and read the display. At both frequencies the readings should be 19 to 23 dB less than the 1 kHz calibrator level.
5. Change the OB-100M filter frequency to 1k and the meter dB RANGE so that the meter reads 20 to 40 dB less than full scale. Press and hold the -20 dB button on the OB-100M. The meter reading shall rise approximately 20 dB to verify that the -20 dB button functions.
6. Remove the calibrator. The analyzer is now ready to use.

### B. Taking a Measurement

1. Turn the meter POWER switch ON. The meter will come on in the Pause mode. Perform a BATTERY test to verify that the analyzer has sufficient battery power. Replace the batteries if the bar indicator falls below the indicating arrow (located at 5 on the 0 - 60 scale).
2. Set the dB RANGE switch to 80 - 140 dB. Set the RESPONSE switch to FAST, WEIGHTING switch to LIN (see note below), and the MODE switch to SPL.  
**NOTE:** Note that the filter response can be in series with either A, B, C, or LIN. This is the operator's choice. However, LIN is generally used when taking octave band measurements.
3. Turn the OB-100M POWER switch to MANUAL to activate the filter. "---" will appear in the display with the meter in the Pause mode.

4. Select the desired WEIGHTING and RESPONSE. Then change the dB RANGE switch down in 20 dB steps until the OL indicator flashes or stays on. Then go back up 20 dB so that the OL indicator stays off. This ensures that the AC input to the filter is at its maximum voltage without clipping (overloading).

#### MANUAL Filter Operation

Place the meter into the Pause mode using the RUN/Pause button. Press RESET to clear all internal memory. Select the first frequency of interest. Then enter the RUN mode for the required amount of time necessary to obtain a valid sample.

Then enter the Pause mode, change to the next frequency of interest and enter RUN again, etc. Repeat this process for all frequencies of interest.

#### AUTO Filter Operation

Place the meter into the Pause mode using the RUN/Pause button. Press RESET to clear all internal memory. Select the first frequency of interest. (Be sure that the TIME adjustment is set to the desired filter cycle time.)

Slide the filter POWER switch to AUTO. To start the sampling sequence, place the meter into the RUN mode and immediately press the proper direction button. (The UP ARROW button causes the frequency to cycle to the next higher frequency, the DOWN ARROW button causes the frequency to cycle to the next lower frequency.)

When the last frequency of interest has completed its cycle time, slide the filter POWER switch to MANUAL and immediately place the meter into the Pause mode.

**NOTE:** If it is necessary to record all 10 frequency bands, exit the AUTO mode while in the last frequency band. Use the MANUAL Filter Operation to obtain the last frequency. Otherwise, the first frequency will be written over.

#### C. Reviewing the Data

To review the data, the meter must be in the Pause mode. Use the Up/Down buttons on the filter to review the frequencies that were measured. Each frequency has the following information in memory: SPL, MAX, MIN, SEL, TIME and LEQ. If an overload occurred during any frequency band measurements, the OL indicator will appear in the display. OL time can then be recalled by first placing the mode switch into the TIME mode and then holding the BATTERY button down.

**NOTE:** Any frequencies that were not measured will appear as "---" in the display when the MODE switch selects either SPL, MAX, MIN, SEL and LEQ. Both TIME and OL TIME will appear as "0:00" since no run time has elapsed.

#### X. TECHNICAL INFORMATION

The OB-100M conforms to ANSI S1.11-1986, Order 3, Type 2, Sub-type C and IEC R225-1966. The normalized passband characteristic of a typical octave filter response is depicted in Figure 20.

The OB-100M filter is flat within 0.5 dB in the passband, with the 3 dB down points at approximately  $.707 f_c$  and  $1.414 f_c$  where  $f_c$  is the center frequency of the band chosen. The  $f_c/2$  and  $2f_c$  frequencies are down by approximately 21 dB with the decade points ( $f_c/10$  and  $10f_c$ ) down by greater than 70 dB.

The block diagram of the OB-100M illustrated in Figure 21 traces the signal input from the Model 2800M through the filters and back to the sound level meter.

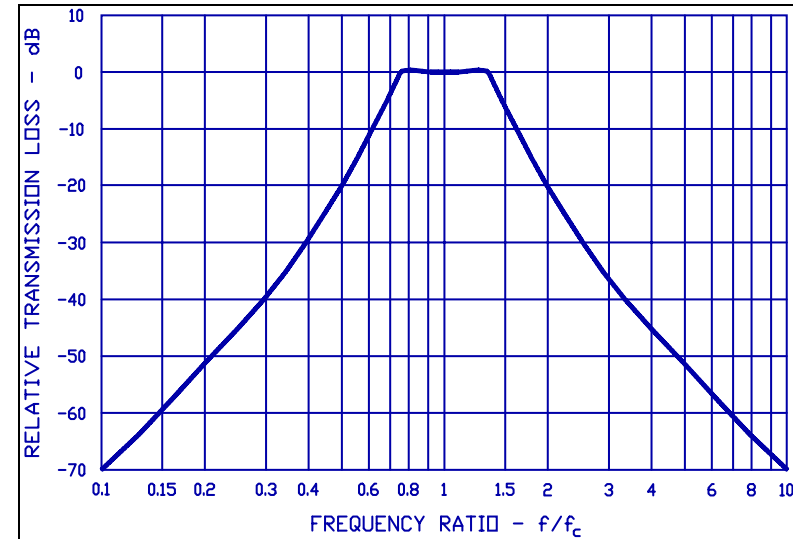

Figure 20. Typical OB-100M Filter Response

**XI. SPECIFICATIONS**

**Standards:** ANSI S1.11-1986, Order 3, Type 2, Sub-type C and IEC R225-1966.

**Center Frequencies:** 10 frequencies from 31.5 Hz to 16 kHz.

**Frequency Selection:** Full manual control or automatic sequential stepping through each frequency.

**Power Source:** Sound Level Meter.

**Size:** 3.3 x 2.8 x 1.8 inches (84 x 71 x 47mm)

**Weight:** 6 ounces (170 grams)

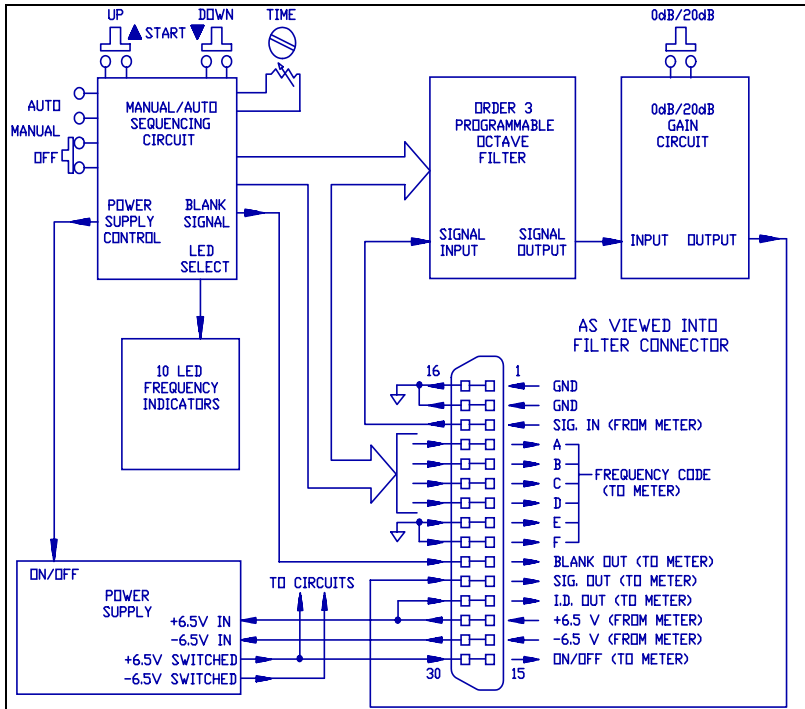

**Figure 21.** Block Diagram Model OB-100 Octave Filter

**XII. INTRODUCTION TO THE MODEL OB-300M**

The Metrosonics Model OB-300M 1/3 - 1/1 Octave Filter is a plug-in module containing a selectable set of filters. The OB-300M meets the most stringent requirements of ANSI S1.11-1986 and IEC R225-1966 for octave and third octave band filters. The unit contains 33 selectable filter frequencies from 12.5 Hz to 20 kHz when in the 1/3 mode and 11 selectable filter frequencies from 16 Hz to 16 kHz when in the 1/1 mode. It may be operated in either the manual or automatic mode.

Primary uses include frequency analysis for product noise emission, material acoustics, community noise, audiometer calibration and analysis of audiometric rooms. Active filters are employed throughout the Model OB-300M, thus permitting the unit to have both high accuracy and compact size.

**XIII. ABOUT THE FILTER**

**A. Filter Controls**

**POWER Switch**

A three position slide switch that does the following:

OFF -- Disconnects the filter circuitry from the attached sound level meter. With this switch in the off position, the OB-300M does not use any power from the meter batteries.

MANUAL -- Filter frequency selection is performed with two push buttons (START Buttons).

AUTO -- Unit automatically cycles through the desired filter frequencies storing sample information for each frequency during the RUN mode.

**START Buttons**

Allow the user to cycle through the different bandpass filters. The two buttons allow manual frequency control (in the MANUAL Mode) or frequency directional control (in the AUTO Mode).

**-20 dB Button**

When this button is depressed, the output of the filter is amplified by exactly 10 times (20 dB) and then fed back to the sound level meter. Therefore, 20 dB has to be subtracted from the meter reading when using this button.

#### MODE Switch

Selects either the 1/3 octave filter set (33 frequencies) or the 1/1 octave filter set (11 frequencies).

#### TIME

A screwdriver adjustment to control the automatic cycle time of each filter frequency from approximately 5 to 30 seconds.

#### B. Filter Connector

The 30 pin connector on the top of the filter is used for connecting the filter to the sound level meter. Figure 22 shows the pinout for the filter connector.

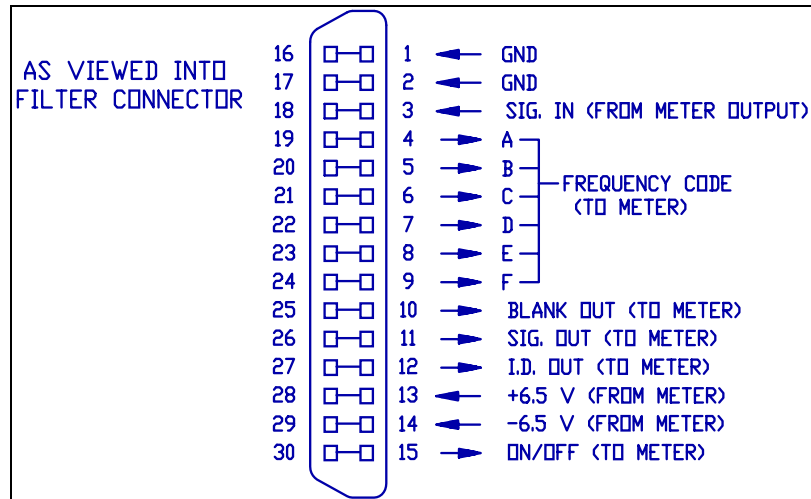

Figure 22. OB-300M External Filter Connector (Located on Top of Filter)

#### XIV. GENERAL OPERATING PROCEDURE

The Model 2800M-300M Octave Band Analyzer is made up of the Model 2800M Impulse Integrating Sound Level Meter and the OB-300M 1/3 - 1/1 Octave Filter Set. The two units are connected together with the long captive screw provided with the filter. The General Operating Considerations for the Model 2800M are basically the same when using the Model OB-300M with the meter.

#### A. Operational Check

The Model 2800M should be calibrated as outlined in Section III of the meter section (Checking the Meter Integrity, B. Calibration) while the OB-300M is OFF. The OB-300M has a fixed input to output voltage ratio of approximately 1 (0 dB) at each center frequency and requires no adjustment. After the meter is calibrated, check the filter for proper operation as follows:

1. Read the calibrator 1 kHz output level. Set the meter dB RANGE switch so that the calibrator level will indicate within the upper 20 dB of the meter display. Set the RESPONSE switch to FAST, WEIGHTING switch to LIN and MODE switch to SPL. Turn the POWER switch to ON.
2. Set the OB-300M POWER switch to MANUAL and the MODE switch to 1/1. Press the RUN button to place the meter into the RUN mode. Then use the two direction buttons to select the 1 kHz filter.
3. Place the calibrator and adapter onto the microphone. Turn the calibrator ON. A meter reading that is very close to the level listed on the calibrator should result. An error of +/- 0.5 dB is acceptable. This is due to the center frequency filter tolerance of +/- 0.5 dB maximum.
4. Change the OB-300M filter frequency first to 500 and read the display. Then change to 2k and read the display. At both frequencies the readings should be 19 to 23 dB less than the 1 kHz calibrator level.
5. Change the OB-300M filter frequency to 1k and the meter dB RANGE so that the meter reads 20 to 40 dB less than full scale. Press and hold the -20 dB button on the OB-100M. The meter reading shall rise approximately 20 dB to verify that the -20 dB button functions.
6. Remove the calibrator. The analyzer is now ready to use.

#### B. Taking a Measurement

1. Turn the meter POWER switch ON. The meter will come on in the Pause mode. Perform a BATTERY test to verify that the analyzer has sufficient battery power. Replace the batteries if the bar indicator falls below the indicating arrow (located at 5 on the 0 - 60 scale).

2. Set the dB RANGE switch to 80 - 140 dB. Set the RESPONSE switch to FAST, WEIGHTING switch to LIN (see note), and the MODE switch to SPL.

NOTE: Note that the filter response can be in series with either A, B, C, or LIN. This is the operator's choice. However, LIN is generally used when taking octave band measurements.

3. Turn the OB-300M POWER switch to MANUAL to activate the filter. "---" will appear in the display with the meter in the Pause mode. Select either 1/3 or 1/1 filters using the MODE switch.
4. Select the desired WEIGHTING and RESPONSE. Then change the dB RANGE switch down in 20 dB steps until the OL indicator flashes or stays on. Then go back up 20 dB so that the OL indicator stays off. This ensures that the AC input to the filter is at its maximum voltage without clipping (overloading).

#### MANUAL Filter Operation

Place the meter into the Pause mode using the RUN/Pause button. Press RESET to clear all internal memory. Select the first frequency of interest. Then enter the RUN mode for the required amount of time necessary to obtain a valid sample.

Then enter the Pause mode, change to the next frequency of interest and enter RUN again, etc. Repeat this process for all frequencies of interest. Note that it is not necessary to enter the pause mode between each frequency if the user just wishes to step through the frequencies sequentially with no delay time in between frequencies.

#### AUTO Filter Operation

Place the meter into the Pause mode using the RUN/Pause button. Press RESET to clear all internal memory. Select the first frequency of interest. (Be sure that the TIME adjustment is set to the desired filter cycle time.)

Slide the filter POWER switch to AUTO. To start the sampling sequence, place the meter into the RUN mode and immediately press the proper direction button. (The UP ARROW button causes the frequency to cycle to the next higher frequency, the DOWN ARROW button causes the frequency to cycle to the next lower frequency.) When the last frequency of interest has completed its cycle time, slide the filter POWER switch to MANUAL and immediately place the meter into the Pause mode.

NOTE: If it is necessary to record all 11 frequency bands (1/1 Mode) or all 33 frequency bands (1/3 mode), exit the AUTO mode while in the last frequency band. Use the MANUAL Filter Operation to obtain the

last frequency. Otherwise, the first frequency will be written over.

#### C. Reviewing the Data

To review the data, the meter must be in the Pause mode. Use the Up/Down buttons on the filter to review the frequencies that were measured. Each frequency has the following information in memory: SPL, MAX, MIN, SEL, TIME and LEQ. If an overload occurred during any frequency band measurements, the OL indicator will appear in the display. OL time can then be recalled by first placing the mode switch into the TIME mode and then holding the BATTERY button down.

NOTE: Any frequencies that were not measured will appear as "---" in the display when the MODE switch selects either SPL, MAX, MIN, SEL and LEQ. Both TIME and OL TIME will appear as "0:00" since no run time has elapsed.

#### XV. TECHNICAL INFORMATION

The OB-300M conforms to ANSI S1.11-1986, Order 3, Type 2, Sub-type C and IEC R225-1966. The normalized passband characteristics of both the 1/1 and 1/3 filter responses are depicted in Figure 23.

The 1/1 filters are flat within 0.5 dB in the passband, with the 3 dB down points at approximately 0.707 fc and 1.414 fc where fc is the center frequency of the band chosen. The fc/2 and 2fc frequencies are down by approximately 21 dB with the decade points (fc/10 and 10fc) down by greater than 70 dB.

The 1/3 filters are flat within 0.3 dB in the passband, with the 3 dB down points at approximately 0.89 fc and 1.12 fc where fc is the center frequency of the band chosen. The fc/2 and 2fc frequencies are down by approximately 50 dB.

The block diagram of the OB-300M illustrated in Figure 24 traces the signal input from the Model 2800M through the filters and back to the sound level meter.

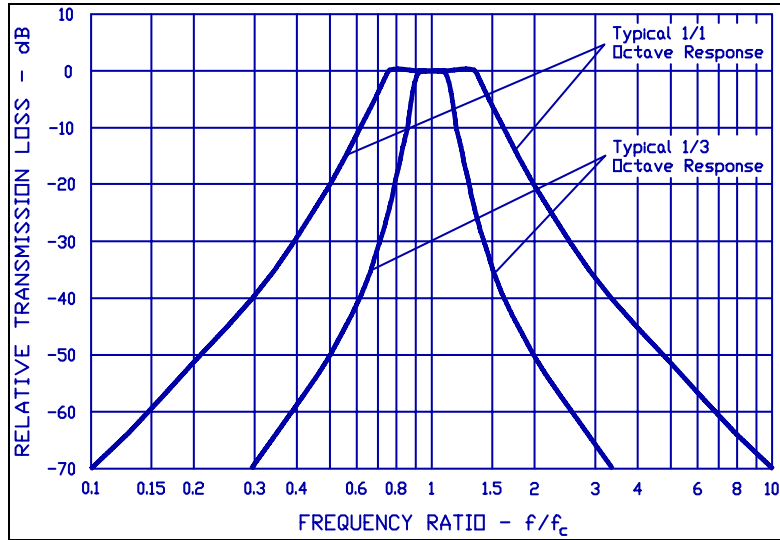

Figure 23. Typical OB-300M Filter Response

**XVI. SPECIFICATIONS**

**Standards:** ANSI S1.11-1986, Order 3, Type 2, Sub-type C and IEC R225-1966.

**Center Frequencies:** (1/3 Mode) 33 frequencies from 12.5 Hz to 20 kHz. (1/1 Mode) 11 frequencies from 16 Hz to 16 kHz.

**Frequency Selection:** Full manual control or automatic sequential stepping through each frequency.

**Power Source:** Sound Level Meter.

**Size:** 3.3 x 4.2 x 1.8 inches (84 x 107 x 47mm)

**Weight:** 9 ounces (255 grams)

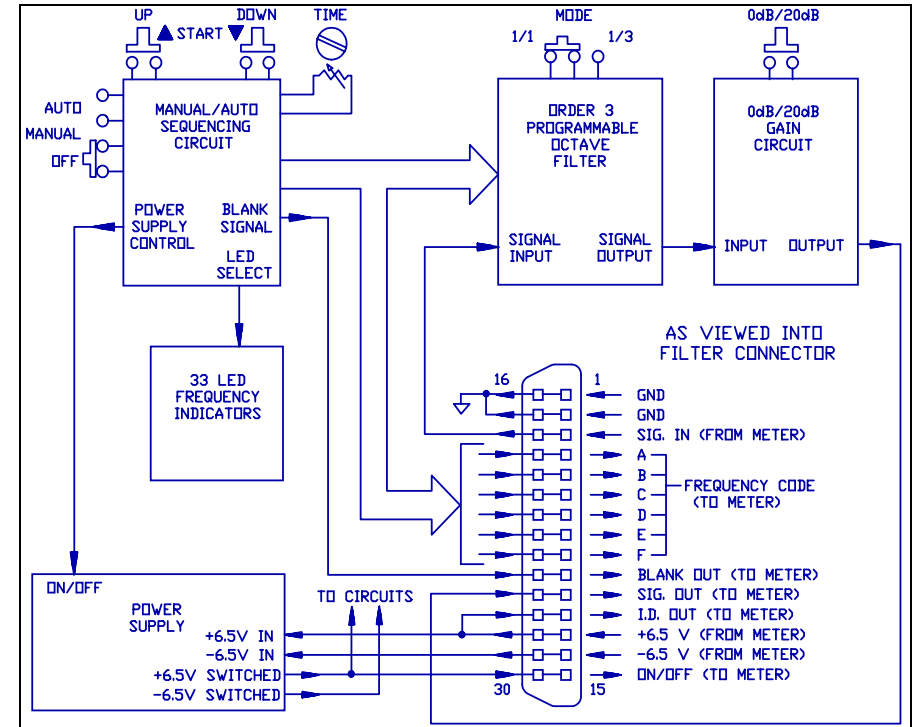

Figure 24. Block Diagram of Model OB-300M

## XVII. ADDENDUM FOR THE MODEL 2800M-5

The Model 2800M-5 Integrating Sound Level Meter is a special purpose integrating meter with an exchange rate of 5dB. This instruction manual is written for an exchange rate of 3dB. This addendum lists the changes in this instruction manual to make it compatible with the 5dB exchange rate meter. They are as follows:

- 1) Wherever the model number "2800M" appears, this is replaced with "2800M-5".
- 2) Both LEQ and SEL function on a 5dB Exchange Rate. Replace "LEQ" with "LEQ (5dB)" and "SEL" with "SEL (5dB)".
- 3) Note that Figure 5 (Sample Printout) values were obtained for the 3dB system.
- 4) SPECIFICATIONS (under Standards): All IEC 804-1984 specifications related to 3dB LEQ (and SEL) are no longer relevant. The meter performs all tests properly under a 5dB exchange rate that is not included in this standard.

When measuring noise in the SPL Mode, a 3dB and 5dB exchange rate meter will read essentially the same.

When measuring steady non-fluctuating noise in the integrating mode, both the 3dB and 5dB exchange rate meters will read essentially the same. However, when the noise is of the impulsive fluctuating variety, the 5dB exchange rate meter will tend to read LEQ (5dB) and SEL (5dB) somewhat lower than the 3dB exchange rate meter.

## SERVICE AND WARRANTY POLICY

### Service Policy

The Metrosonics product you have purchased is one of the finest acoustic instruments available. It is backed by our full one year warranty which seeks complete customer satisfaction. This is your assurance that you can expect prompt courteous service for your equipment from the entire Metrosonics service organization.

Should your Metrosonics equipment need to be returned for repair or recalibration, please contact the Service Department at 1(800)245-0779 (USA) or Fax (262)567-4047 for a Return Authorization Number. The RA number is valid for 30 days, and must be shown on the shipping label and purchase order/cover letter. If you are unable to return instruments in that time call for a new RA number.

Repair or replacement work done under warranty will be performed free of charge, and the instrument will be returned to you freight prepaid. Your copy or a photocopy of the Warranty Registration Card will serve as proof of warranty should the factory require this information.

If for any reason you should find it necessary to contact the factory regarding service or shipping damage, please direct your calls or letters to the attention of Customer Service, Quest Technologies, (262) 567-9157 or (800) 245-0779. Office hours are from 7 AM to 6 PM (Central Standard Time) Monday through Friday.

For service or recalibration outside the U.S.A. please contact your local Metrosonics dealer or contact the factory.

### Warranty Policy

Quest Technologies warrants Metrosonics instruments to be free from defects in materials and workmanship for one year under normal conditions of use and service. For U.S.A. customers we will replace or repair (our option) defective instruments at no charge, excluding batteries, abuse, misuse, alterations, physical damage, or instruments previously repaired by other than Metrosonics. Microphones, sensors and printers may have shorter warranty periods. This warranty states our total obligation in place of any other warranties expressed or implied. Our warranty does not include any liability or obligation directly resulting from any defective instrument or product or any associated damages, injuries, or property loss, including loss of use or measurement data.

For warranty outside the U.S.A., a minimum of one year warranty applies to the same limitation and exceptions as above with service provided or arranged through the authorized Metrosonics distributor. Foreign purchasers should contact the local Metrosonics distributor for details.